

4

3

2

1

REVISION HISTORY					
REV	DESCRIPTION	BY	CHK	ENG	ENG MGR
0	RELEASED FOR CONSTRUCTION	M.D.C.	RJW	RJW	BE
		10-7-05	10-12-05	10-12-05	10-14-05

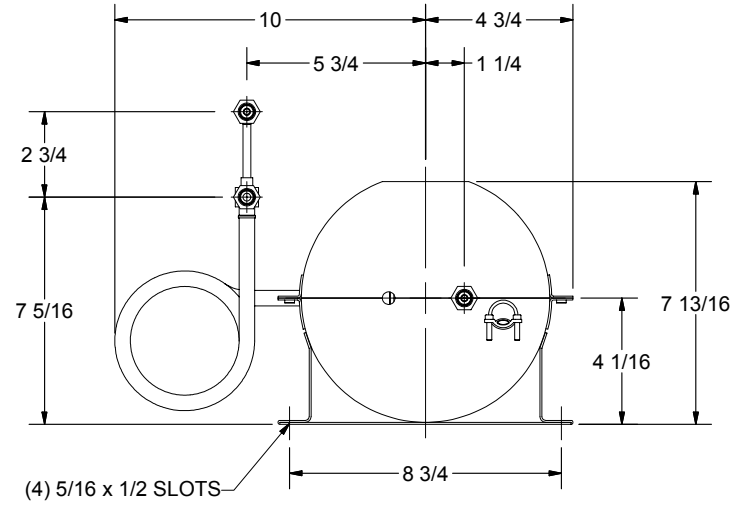
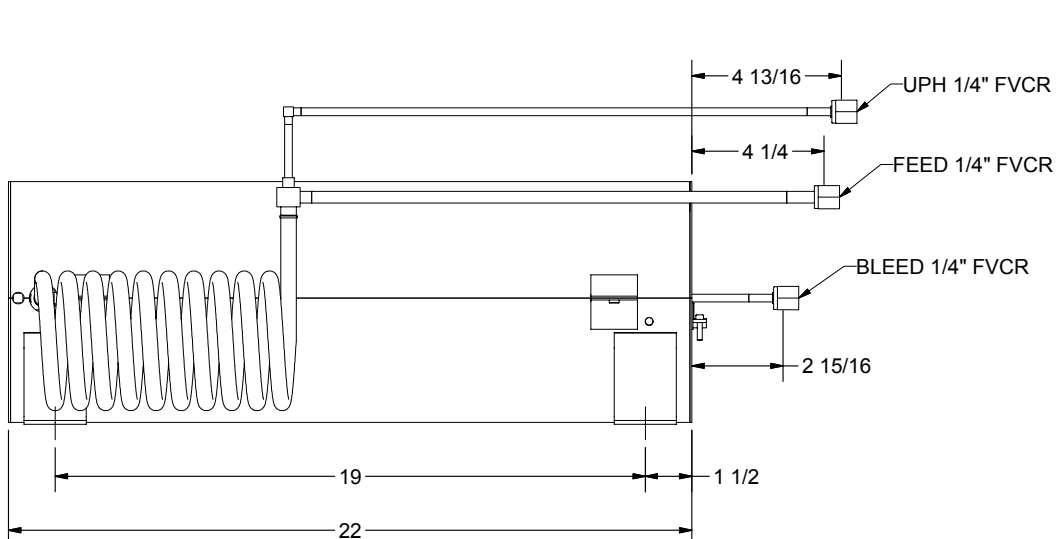

**NOTES:**

1. MAKE FROM HP-D-8834.

PROPERTY OF JOHNSON MATTHEY, INC. TO BE RETURNED UPON REQUEST AND USED ONLY IN REFERENCE TO CONTRACT OR PROPOSALS OF THIS CORPORATION. UNAUTHORIZED REPRODUCTION IS PROHIBITED.



THIRD ANGLE PROJECTION

DIMENSION LIMITS (UNLESS OTHERWISE SPECIFIED)			
DIMENSION	UP TO	15.001 [380] TO	OVER
IN	[mm]	30.000 [760]	30.001 [760]
0.0	[0]	± 0.05 [1]	± 0.1 [2.5]
0.00	[0.0]	± 0.015 [4]	± 0.030 [8]
0.000	[0.00]	± 0.005 [0.13]	± 0.010 [0.26]
FRACTION		± 1/32	± 1/16

**OUTLINE DRAWING, HP-400/480, WITH PASSIVE PREHEATER**



GAS PURIFICATION TECHNOLOGY  
WEST CHESTER, PA

DESIGN		ENG.	PRO. ENG.	ENG. MGR.
DRAWN M.D.C.	CHECKED RJW 10-12-05	RJW 10-12-05	X	BE 10-14-05
DATE: 10-7-05	SHEET NO. 1 OF 1	DRAWING NUMBER		REV.
SCALE 3" = 1'-0"		HP-B-8835		0

4

3

2

1