

REVISION HISTORY					
REV	DESCRIPTION	BY	CHK	ENG	ENG MGR
0	RELEASED FOR CONSTRUCTION	M.D.C. 2-2-10	JKS 2-4-10	JKS 2-4-10	NDP 2-5-10
1	REVISED BLEED 3.13 WAS 3.32, ADJ. UPH & FEED TO MATCH	M.D.C. 2-5-10	JKS 2-9-10	NDP 2-8-10	NDP 2-8-10

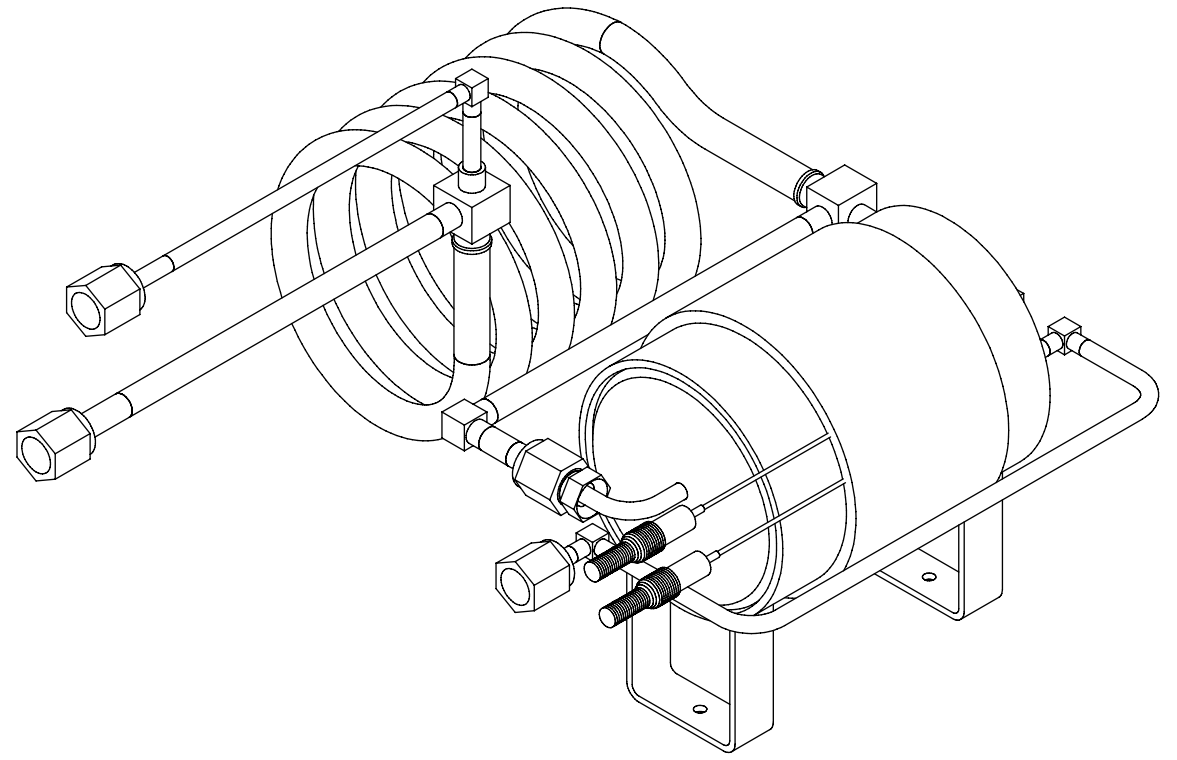

NOTES:

1. MAKE FROM DWG. HP-D-9954.

PROPERTY OF JOHNSON MATTHEY, INC. TO BE RETURNED UPON REQUEST AND USED ONLY IN REFERENCE TO CONTRACT OR PROPOSALS OF THIS CORPORATION. UNAUTHORIZED REPRODUCTION IS PROHIBITED.

THIRD ANGLE PROJECTION

DIMENSION LIMITS (UNLESS OTHERWISE SPECIFIED)			
DIMENSION	UP TO	15.001 [380] TO	OVER
IN [mm]	15.000 [380]	30.000 [760]	30.001 [760]
0.0 [0]	± 0.05 [1]	± 0.1 [2.5]	± 0.1 [2.5]
0.00 [0.0]	± 0.015 [0.4]	± 0.030 [0.8]	± 0.045 [1.12]
0.000 [0.00]	± 0.005 [0.13]	± 0.010 [0.26]	± 0.015 [0.40]
FRACTION	± 1/32	± 1/16	± 1/8

**GENERAL ARRANGEMENT,
HP-100 CELL**

JM Johnson Matthey
GAS PURIFICATION TECHNOLOGY
WEST CHESTER, PA

DESIGN	ENG.	PRO. ENG.	ENG. MGR.
M.D.C.	JKS 2-4-10		NDP 2-5-10
DATE: 2-2-10	DRAWING NUMBER		REV.
SHEET NO. 1 OF 1	HP-B-9955		1
SCALE: 3/8" = 1"			