

REVISIONS			
REV.	DESCRIPTIONS	BY	APPVD.
0	RELEASED FOR CONSTRUCTION	M.D.C. 10-17-01	W.B. 10-24-01

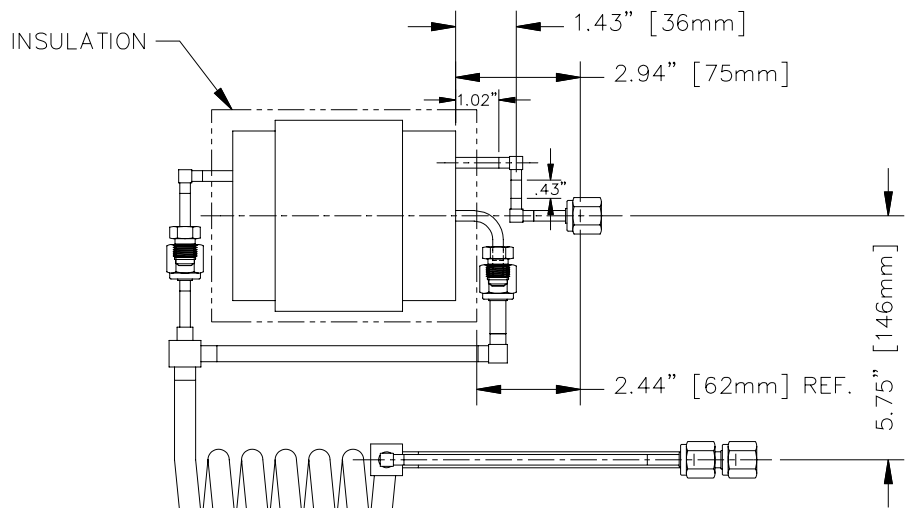

NO.	QTY.	SOURCE NO.	DESCRIPTION
1	1	-	CELL ASSEMBLY, DWG. HP-D-6169
2	2	5062	FEMALE NUT, CAJON SS-4-VCR-1
3	2	6601	SHORT TUBE BUTT WELD GLAND, CAJON 316L-4-VCR-3S-4TB7
4	3	6806	UNION ELBOW, CAJON 6LV-4MW-9
5	1	6848	SHORT TUBE BUTT WELD GALND, CAJON 6LV-4-HVCR-3S-6TB7
6	1	6859	FEMALE NUT, CAJON SS-4-HVCR-1
7	.6'	6138	TUBING ELECTROPOLISHED, 1/4" O.D. x .035" WALL
8	.6'	6139	TUBING ELECTROPOLISHED, 3/8" O.D. x .035" WALL
9	2	6958	FOOT BRACKET, DWG. 09-0A4113

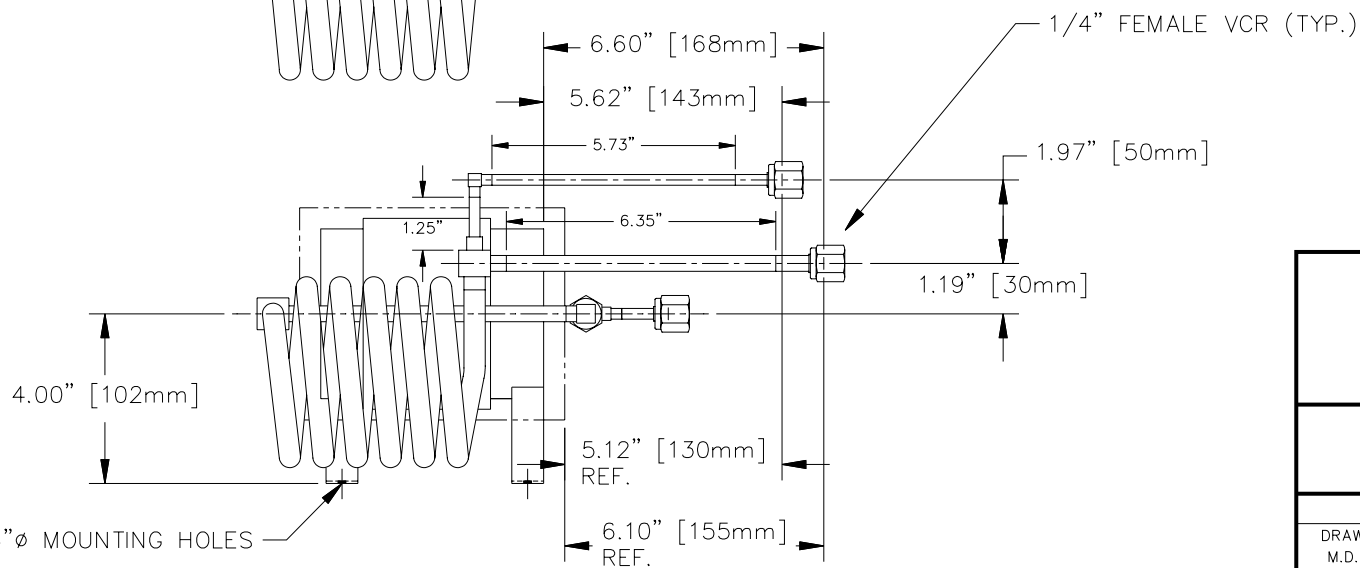

HP-100 CELL  
OUTLINE DRAWING

**Johnson Matthey**  
 GAS PROCESSING TECHNOLOGY  
 WAYNE, PA

DESIGN		ENGR.	PRO. ENGR.	ENGR. MGR.
DRAWN M.D.C.	CHECKED W.B.			
DATE: 10-9-01	SHEET NO. 1 OF 1	DRAWING NUMBER		REV.
SCALE 1" = 3"		HP-B-6780		0

PROPERTY OF JOHNSON MATTHEY, INC. TO BE RETURNED UPON REQUEST AND USED ONLY IN REFERENCE TO CONTRACTS OR PROPOSALS OF THIS CORPORATION. UNAUTHORIZED REPRODUCTION IS PROHIBITED.